



AIR COOLED CHILLER

Model MM180

Item #147701

INSTRUCTION MANUAL



October 2010
IMS Company
10373 Stafford Road
Chagrin Falls, OH 44023-5296

Telephone: (440) 543-1615
Fax: (440) 543-1069
Email: sales@imscompany.com
Website: www.imscompany.com



AIR COOLED CHILLER INSTALLATION and OPERATION MANUAL

TABLE OF CONTENTS

General Information	3
Installation	3
Basic Chiller Components	4
Pre-Startup Procedure	5
Initial Startup & Operation	5
Maintenance / Spare Parts	6
Fluid Recommendations	7
Troubleshooting	9
Warranty Procedures	11
Warranty	12
Unit Specific Information:	14
MSDS	
Temperature Controller Guide	
Drawings	

GENERAL INFORMATION REGARDING DESIGN TEMPERATURE

Our custom chiller systems are designed to maintain the temperature of cooling fluids within a selected temperature range. Each of our units is tested through monitored operation within design parameters. This enables our experienced technicians to calibrate all instrumentation precisely to the customers needs and verify that each individual unit will function as specified. Supporting test data is enclosed either in digital format or in print.

The units are designed to operate efficiently within given parameters. Due to varying heat exchange rates outside of design temperature, it is highly recommended that the machine operate only at temperatures within 10°F of the specified temperature. **Consult the factory if a process requires changes in excess of 10°F in either direction of design temperature.**

INSTALLATION:

1. Read and follow all information included with the chiller manual.
2. Read and understand all warning labels and tags on the chiller before installation.
3. Ensure the unit is placed on a flat, level, hard surface. Unless the chiller has been built for outdoor operation, it must be placed indoors. Space above and around the unit must be capable of dissipating the heat rejected by the chiller and allow room for servicing. Keep the unit at least 3ft away from walls or other objects and allow full access to all openings and electrical enclosures. At a minimum, 8ft of clearance is required above the unit for proper air circulation around the chiller as shown in Fig 1.
4. Chillers with solid feet should be secured using the provided mounting holes if possible. Units that have caster wheels should be locked to ensure the chiller does not move around.

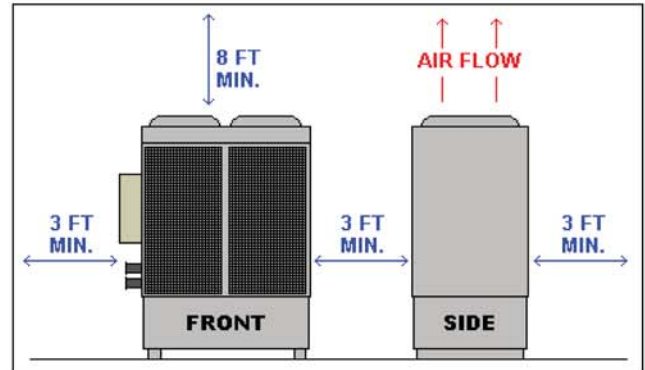



Figure 1. Minimum Installation Clearances

5. Connect fluid lines to the proper fittings from the process to the chiller marked "FLUID INLET TO CHILLER" and "FLUID OUTLET FROM CHILLER". Make sure that the flow of fluid to and from the unit can not be shut off or blocked while the chiller is in operation. Piping size should be large enough to match the fluid flow conditions, generally the size of the fittings on the chiller.
 6. Fill the process plumbing and, if applicable, the chiller reservoir with the proper type and amount of fluid. **Check with the manufacturer of the process equipment for specific fluid requirements. Refer to the "Process Fluid Recommendations" section of the manual for information on using water in the chiller.**
 7. Purge any air out of the fluid system to ensure that the pump suction is flooded. If possible, bleed any air trapped in the pump by opening the vent plug at the top of the pump until no more air comes out and fluid is present in the pump cavity.
- DO NOT ALLOW THE FLUID PUMP TO RUN DRY. THIS WILL DAMAGE THE PUMP SEALS AND WILL NOT BE COVERED UNDER WARRANTY.**
- 
8. Connect any communication wiring between the chiller and process equipment including remote controls and interlocks. All communication and remote wiring is to be provided by the customer. Refer to the chiller's electrical prints for information on wiring locations.

9. Run power wiring to the chiller's main disconnect. Conductor size should match the chiller's disconnect size and power requirements in accordance with local codes. Ensure the power supplied matches the chiller data plate requirement for voltage, frequency, and amperage.
10. All inclusive units are shipped with the proper refrigerant charge in place. No adjustments

should be necessary to the refrigeration system before startup. Refrigeration service valves are shipped in the open (back-seated) position.

11. Chillers with a remote condenser are shipped with a nitrogen charge from the factory. Refer to the included refrigeration drawing or contact Industrial Molding Supplies (IMS) for instructions on installing remote condenser units.

BASIC COMPONENTS:

Refer to Figure 2 for identification of the main parts on a standard IMS chiller. Please note that this is only a general representation of components and the model of your chiller may differ from the design shown. Contact Industrial Molding Supplies for specific component information regarding your chiller.

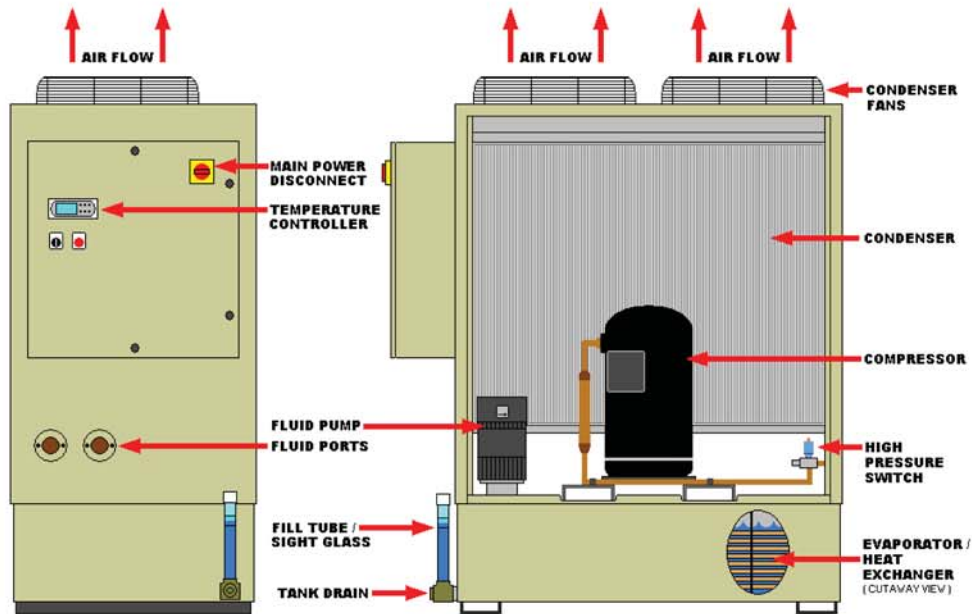

Figure 2. Basic Air-Cooled Chiller Components

PRE-STARTUP PROCEDURE:

1. Complete all steps of the *installation* process before applying power to the chiller.
2. If the unit is equipped, ensure the system switch is in the OFF position, then turn on the main power disconnect. The temperature controller will turn on and automatically go into a self-test. When the self-test is complete, the controller will begin to monitor the process fluid.
3. For units that run on three-phase power, **motor rotation must be checked and corrected to avoid damaging the chiller and voiding the warranty.** If the chiller is equipped with a phase protector, the unit will not start up and may display a fault if phase rotation is not correct. Correcting phase rotation should make this fault go away.

Single phase units will not be affected by any certain phase rotation and should continue on with step 4 of the *pre-startup procedure*.

If the unit is equipped with a process fluid pump, phase rotation can be checked by briefly turning on the system and allowing the pump to energize. Watch the rotation of the cooling fan on the pump to see that it is turning in the direction indicated by the rotation arrow on the pump motor. Do not use condenser fans to judge phase rotation as many three phase units have single phase fans and will run correctly from IMS even with incorrect power phasing.

If the unit does not have a pump or any other visual method of checking rotation, a phase checking device can be used to check power at the disconnect. All components of the chiller are wired to operate with a "right-hand" phase rotation. If you do not have a phase checking device, a certified refrigeration technician should be utilized to monitor refrigerant pressures as the chiller compressor comes online.

All motors within the chiller are synchronized at the factory for proper rotation. If one motor is turning in the wrong

direction, all other motors will as well. **DO NOT** change the orientation of any motor leads within the chiller. If phase rotation is incorrect, shut off the power feed and change any two incoming power leads BEFORE the main disconnect.

4. Chillers two tons or larger are equipped with a compressor crankcase heater. These units must have power supplied to the unit with only the disconnect switch on for 8 hours prior to starting the chiller. This will raise the temperature of the compressor oil enough to vaporize any refrigerant that may be in the crankcase oil.  **Failure to allow this warm-up can result in compressor damage.**
5. Ensure all process fluid lines and shutoff valves are open and the system is able to flow freely. Re-check the fluid level in the system before continuing with the startup.

INITIAL STARTUP & OPERATING PROCEDURE:

1. Complete all steps of the *pre-startup procedure* before starting the chiller process.
2. Before turning on the chiller system, become familiar with the operation of the temperature controller on the chiller. Refer to the *temperature controller guide* in this manual for instructions.
3. Turn on the chiller process by moving the selector switch to either ON or LOCAL. If the unit is wired to start remotely, turn the selector switch to REMOTE and start the chiller from the other location.

Chillers that do not have a process selector switch or remote control should begin the chilling process as soon as the disconnect switch is turned on.

4. If the unit is equipped with a process pump, it will energize and produce flow as soon as the

chiller is turned on. Monitor any system pressure gauges and make note of initial pressures. The pump may need to run for several minutes to allow any air to be worked out of the system before regular flow is established. Any fluid bypass valves in the system should be factory set according to customer specifications but may need slight adjustment in the field. **Consult the factory before making any adjustments to the system.**

5. Check the entire fluid system for leaks and ensure there is flow throughout the system.
6. After the pump turns on, the temperature controller will then analyze the process fluid temperature and determine whether or not cooling is needed. If the fluid temperature is above setpoint, the refrigerant compressor will commence and begin cooling the fluid.
7. Monitor the chiller to ensure it is performing as designed. The chiller should be able to maintain the desired fluid setpoint under a full load from the process. Slight adjustments may be necessary according to your specific process. Please consult a technician at Industrial Molding Supplies before making any changes to the unit.
8. To turn off the chiller process, move the selector switch to the OFF position. With the selector OFF, the temperature controller display will be on to monitor the process, but indicate the system is off. **Keep the chiller's main power-disconnect ON even when the chiller is not in use**, unless it is used to turn the chiller process off and on. This keeps the power to the crankcase heater and prevents compressor damage when starting again.



If the unit is equipped with a fluid maintenance heater, the heater will operate if the fluid falls below the factory setpoint and will operate with the selector switch off.

MAINTENANCE AND SPARE PARTS:

Proper maintenance is the key to extending the life of your chiller. Routine checks and a watchful eye will minimize costly repairs and down time. Establish a regular schedule of maintenance depending on the amount the chiller is used and the environment in which it is used. Environments that are very dirty or dusty will require more attention than ones that maintain a cleaner atmosphere.

This list of maintenance items will help to ensure an operational chiller:

1. Inspect and clean condenser / air filters

Excessive buildup of dirt, oil, and other debris on the condenser coil will cause refrigerant pressures to increase and not allow the unit to perform to its full capacity. Ensure the fins of the condenser are clean and not damaged to keep airflow at a maximum. Use compressed air at no more than 30PSI to blow out the condenser in the opposite direction of air flow. If the unit is equipped with air filters, clean them with compressed air or wash them out with water and allow drying before reinstallation.

2. Check water quality/glycol mixture

The process fluid should be clean and free of contaminants. If the chiller has a reservoir, check for debris or contaminants which could reduce the efficiency of your chiller. Check for normal inlet and outlet fluid pressures through the chiller. A large pressure differential could indicate a plugged heat exchanger or dirty tank. Test the process fluid to ensure proper freeze and corrosion protection in accordance with original design specifications. Do not test the process fluid from the sight glass due to the lower turnover at that location.

3. Inspect fluid filters

Fluid filters should be clean enough to allow for proper flow and pressure in the system. An increased fluid pressure on the system may indicate a dirty filter. Replacement of fluid filters should be done at regular intervals to keep the fluid system clean and free flowing. Inspect fluid filters shortly after initial start-up of the chiller and establish a basis for how frequently they may need to be changed in the future.

4. Inspect fluid system

Visually check for fluid leaks throughout system. Physically check for loose pipe fittings or hoses. Ensure that no plumbing parts are wearing, cracking, or chafing.

5. Check voltage & amp draws

Check for proper incoming voltage and current draws on all motors and heaters. Refer to the chiller's electrical schematics or the motor nameplate for proper voltage and amperage ratings. Readings should be within +/- 10% of the nameplate and have a maximum difference of +/- 2% between each phase.

6. Inspect mechanical components

Check mechanical components of the chiller for signs of wear or over-heating. Metallic sounds or other excessive noise could indicate a problem with the chiller. Discolored paint or metal could be a sign of a motor under excessive load and over-drawing current. Keep all components with lubrication fittings properly filled according to the nameplate data or information tag.

7. Check all wiring

Ensure the chiller's main power disconnect is OFF. Check the electrical box and all junction boxes for any loose or damaged wiring. Replace any wiring that could cause problems with shorting or unintentional grounds.

8. Inspect/test refrigeration system

Check the inside of the chiller for evidence of refrigerant leaks. Spots of oil inside of the chiller or refrigeration lines covered in oil could indicate a possible leak. Have a certified refrigeration technician check the refrigeration system for proper operation. The technician should leak check the unit, monitor operating pressures, and adjust as needed.

PROCESS FLUID RECOMMENDATIONS:

For recommendations on the correct process fluid to use in your chilling system, refer to the manufacturer of the equipment served by the chiller. Most manufacturers have a specified type of fluid for correct system operation. This document should serve as a guide only when using a glycol and water mixture for the heat transfer fluid.

USING WATER FOR CHILLER PROCESS:

Industrial Molding Supplies recommends the use of an industrial inhibited glycol and water mixture in its water chiller systems. The main job of glycol is to prevent freezing of the process fluid and ensure consistent flow at the operating temperature. Inhibited glycols will also prevent formation of scale and corrosion while protecting metals such as brass, copper, steel, cast iron, and aluminum. Water systems treated with inhibited glycol will also be protected from algae and bacteria that can grow and degrade the fluid system performance. **Ethylene** and **Propylene** are the two standard types of inhibited glycols that can be used in IMS chillers.

- Do not mix different types or brand names of glycol as this can result in some inhibitors precipitating out of the solution.
- Do not use automotive grade anti-freeze in the chiller process. These types of glycols are not designed for industrial applications and may cause problems with heat transfer or fluid flow. Many automotive glycols contain silicate-based inhibitors that can coat heat-exchangers, attack pump seals, or form a flow restricting gel.

Check state and local codes when selecting the process fluid. Certain areas may have environmental regulations concerning the use and disposal of glycol or other additives.

ETHYLENE GLYCOL:

Ethylene glycol is the standard heat-transfer fluid for most industrial applications. This type of glycol can be used in any application where a low-toxicity content is not required. Ethylene glycol has moderately acute oral toxicity and should not be used in processes where the fluid could come in



contact with potable water, food, or beverage products.

PROPYLENE GLYCOL:

Propylene glycol maintains generally the same freeze protection, corrosion and algae prevention as ethylene glycol, but has a lower level of toxicity. This type of glycol is more readily disposable than ethylene and safer to handle. Propylene glycol is commonly used in the food industry and in applications where the user may come in frequent contact with the fluid.

WATER:

When selecting the water to mix with the glycol, use a good quality, filtered source that meets the requirements of the process machine manufacturer. Industrial Molding Supplies recommends the use of **distilled** or **reverse-osmosis** water for the water / glycol mixture.

De-ionized water can be used to fill the chiller process initially, but should not be maintained to a de-ionized state thereafter. Unless the chiller has been ordered and designed for the use of water that is continually de-ionized, the fluid will actually attack certain metals within the chiller and cause damage to some components. Damage caused by

the use of maintained de-ionized water in a chiller not designed for it will not be covered under warranty. Consult IMS before continuously using de-ionized water to check for compatibility.

The use of regular tap water is not recommended. Water from the "city" or "ground" contains deposits and additives which can decrease component life and increase maintenance time.

GLYCOL / WATER MIXTURES:

The location of the chiller and environmental concerns must be taken into account when selecting the proper mixture of glycol and water for the chiller process. A process which is located completely indoors and has no chance of freezing will require less glycol than a system located outdoors where low temperatures can cause the fluid to freeze and piping to burst. Applications that have a low operating temperature (below 30°F) should use a glycol mixture equivalent to an outdoor system.

After selecting the proper glycol and water types, use the following chart to determine the recommended mixture depending on application and location of the process. The glycol percentage figures in the chart below will apply to any brand of ethylene or propylene glycol.

APPLICATION	GLYCOL %	WATER %	FREEZE PROTECTION	BURST PROTECTION
Indoor chiller and process	30	70	5°F / -15°C	-20°F / -29°C
Outdoor chiller / Low fluid temperature system (<30°F)	50	50	-35°F / -37°C	-60°F / -60°C

FLUID MAINTENANCE / FILTRATION:

Maintaining clean process water and the proper glycol content will extend the life of the system and reduce costly down-time. If the chiller was not equipped with a fluid filter from the factory, it is highly recommended to install some sort of filtering system to remove unwanted dirt and debris. Refer to the *Chiller Maintenance* section of the manual for water and filter maintenance information.



TROUBLESHOOTING GUIDE:

- This guide should serve as a general outline for troubleshooting issues with all Industrial Molding Supplies chillers. Due to the various models of IMS chillers, the items listed in *possible causes* may not apply to every IMS chiller.
- Refer to the *Warranty Procedures* section of this manual before having any work performed on units that are under warranty.

PROBLEM	POSSIBLE CAUSE	CORRECTIVE ACTION
Chiller will not turn on. (No display on temperature controller)	<ul style="list-style-type: none"> • No power to chiller. • Main disconnect turned off. • Blown fuses. • Tripped starter overloads. 	<ul style="list-style-type: none"> • Check power feed to chiller. • Turn on main disconnect. • Check for and replace blown fuses. • Reset any tripped overloads.
Chiller turns on but nothing happens. (Display is on but no pump or cooling cycle)	<ul style="list-style-type: none"> • Selector switch not turned on. • Remote signal not active. • Fault present within chiller. • Fluid pump not operating. • Blown fuses. • Phase rotation incorrect. 	<ul style="list-style-type: none"> • Turn selector switch to ON or LOCAL. • Check remote connection for signal. • Determine fault and clear if possible. • Check pump overload and power to contactor. • Check and replace fuses. • Correct phase rotation at main disconnect.
Fluid pump is on but does not create required pressure or flow. (Flow fault)	<ul style="list-style-type: none"> • No fluid present at pump suction. • Pump discharge closed or blocked. • Fluid is dirty / dirty filters. • Fluid line size too small. • Pump / fluid system is air-bound. • Phase rotation incorrect. 	<ul style="list-style-type: none"> • Check fluid level and ensure there is fluid at the pump's suction. • Ensure all fluid lines are open to flow. • Clean fluid and change filters. • Up-size fluid lines outside of chiller. • Vent pump cavity to flood the suction. • Correct phase rotation at main disconnect.
Fluid pump is operational but the refrigerant compressor will not run.	<ul style="list-style-type: none"> • Fluid temp is below setpoint. • Inadequate fluid flow. • Low refrigerant pressure. • High refrigerant pressure. • Compressor overload tripped. • Compressor lube protector tripped (If equipped). • Blown fuses to compressor. • Faulty temp controller output. • Bad compressor. 	<ul style="list-style-type: none"> • Allow fluid system to increase in temperature. • Correct fluid system to establish flow. • SEE "Low refrigerant fault" section. • SEE "High refrigerant fault" section. • SEE "Compressor overload" section. • Reset lube protector. • Check and replace blown fuses. • Consult IMS customer service department. • Consult IMS customer service department.
Chiller is running but does not maintain the desired fluid temp.	<ul style="list-style-type: none"> • Fault present within chiller. • Phase rotation incorrect. • Fluid or heat exchanger is dirty. • Loss of flow or fluid level. • Low refrigerant pressure. • Ambient temperature too high. • Heat load exceeds chiller's capacity. 	<ul style="list-style-type: none"> • Determine fault and clear if possible. • Correct phase rotation at incoming power. • Replace fluid and clean fluid system. • Check fluid system for free flow and ensure chiller has adequate fluid level. • Restart chiller or clear fault on controller. SEE "low refrigerant fault" section. • Ensure chiller is operating within its designed ambient temperature specification. • Reduce heat load to chiller if possible. Check the factory specifications to ensure the chiller is not being operated more than +/- 10°F of the original temperature setpoint or fluid flow.

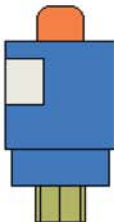
<p>Low refrigerant pressure fault - (<u>Automatically reset when satisfied with pressure</u>)</p>	<ul style="list-style-type: none"> • Low ambient air temperature. • Loss of fluid flow through evaporator. • Loss of refrigerant. • Refrigerant solenoid not functional. • Faulty pressure switch. • Compressor crankcase not warm or faulty crankcase heater. 	<ul style="list-style-type: none"> • Ensure chiller is operating within its designed ambient temperature specification. • Check fluid flow and ensure evaporator is clean. • Have a refrigerant technician leak check unit and charge with the appropriate refrigerant. • Check wiring to solenoid or replace valve. • Replace pressure switch. • Ensure main power disconnect has been on for at least 8 hours prior to use. Replace crankcase heater if faulty.
<p>High refrigerant pressure fault - (<u>Manually reset inside of chiller</u>)</p>  <p>(Example of a high pressure switch shown)</p>	<p><u>AIR COOLED CHILLERS:</u></p> <ul style="list-style-type: none"> • Air filters dirty. • Condenser dirty. • Incoming air too hot. • Inoperative fans. • Back panel out of chiller. • Phase rotation incorrect. • Refrigerant system overcharged. <p><u>WATER COOLED CHILLERS:</u></p> <ul style="list-style-type: none"> • Low water flow to condenser. • Condenser dirty. • Regulating valve operating incorrectly. • Refrigerant system overcharged. 	<ul style="list-style-type: none"> • Clean filters (See maintenance section). • Clean condenser (See maintenance section). • Ensure the chiller is properly ventilated with fresh air not exceeding 90°F, unless designed for high-ambient temperature operation. • Check for blown fan fuses. • Ensure all covers and panels are in chiller. • Correct phase rotation at incoming power. • Have a refrigeration technician ensure the system is properly charged. • Check condenser water supply and pressure. • Clean condenser. • Have a refrigeration technician adjust the valve to the proper pressure setting and check operation. • Have a refrigeration technician ensure the system is properly charged.
<p>Compressor overload - (<u>May be manually or automatically reset, depending on compressor</u>)</p>	<ul style="list-style-type: none"> • Compressor running too hot. • Temperature setpoint too high. • Refrigerant pressures too high or low. • Faulty overload module. • Low voltage to chiller. • Defective compressor. 	<ul style="list-style-type: none"> • Allow compressor to cool, then restart unit. • Move temperature setpoint to +/- 10°F of factory setting. • Have a refrigeration technician monitor pressures and determine cause. • If compressor will run, check amp draw on compressor leads to verify compressor is ok. • Correct incoming voltage. • Replace compressor.



DuPont Chemicals



DuPont Chemicals

2187FR

Revised 12-APR-1996

Printed 19-AUG-1997

"SUVA" 134A

CHEMICAL PRODUCT/COMPANY IDENTIFICATION

Material Identification

Corporate MSDS Number	DU000693
CAS Number	811-97-2
Formula	CH2FCF3
CAS Name	" SUVA " 134A

Tradenames and Synonyms

HCF 134A
VT1505

Company Identification

MANUFACTURER / DISTRIBUTOR
DuPont
1007 Market Street
Wilmington, DE 19898

PHONE NUMBERS

Product Information	1-800-441-7515
Transport Emergency	CHEMTREC: 1-800-424-9300
Medical Emergency	1-800-441-3637

COMPOSITION/INFORMATION ON INGREDIENTS

Components

Material	CAS Number	%
*ETHANE, 1, 1, 1, 2-TETRAFLUORO- (HFC-134a).		811-97-2 100

HAZARDS IDENTIFICATION

Potential Health Effects

INHALATION

ETHANE, 1,1,1,2-TETRAFLUORO-

Gross overexposure may cause: Central nervous system depression with dizziness, confusion, incoordination, drowsiness or unconsciousness. Inhalation of high concentrations of vapor is harmful and may cause heart irregularity unconsciousness or death. Intentional misuse or deliberate inhalation may cause death without warning. Vapor reduces oxygen available for breathing and is heavier than air. Liquid contact can cause frostbite.

HUMAN HEALTH EFFECTS:

SKIN CONTACT

ETHANE, 1,1,1,2-TETRAFLUORO-

Immediate effects of overexposure may include frostbite. If liquid or escaping vapor contacts the skin. Frostbite-like effects may occur if the liquid or escaping vapors contact the eyes.

Inhalation may include temporary nervous system depression with anesthetic effects such as dizziness, headache, confusion, incoordination, and loss of consciousness.

Higher exposures may lead to temporary alteration of the heart's electrical activity with irregular pulse, palpitations, or inadequate circulation. Fatality may occur from gross overexposure.

Individuals with preexisting diseases of the central nervous or cardiovascular system may have increased susceptibility to the toxicity of excessive exposures.

CARCINOGENICITY INFORMATION

None of the components present in this material at concentrations equal to or greater than 0.1% are listed by IARC, NTP, OSHA or ACGIH as a carcinogen.

FIRST AID MEASURES

First Aid

INHALATION

If inhaled, immediately remove to fresh air. Keep person calm. If not breathing, give artificial respiration. If breathing is difficult, give oxygen. Call a physician.

SKIN CONTACT

In case of contact, immediately flush area with plenty of lukewarm water for at least 15 minutes, while removing contaminated clothing and shoes. Call a physician. Wash contaminated clothing before reuse. Treat for frostbite if necessary by gently warming affected area.

EYE CONTACT

In case of contact, immediately flush eyes with plenty of water for at least 15 minutes. Call a physician.

FIRST AID MEASURES CONTINUED,

INGESTION

Ingestion is not considered a potential route of exposure.

Notes to Physicians

Because of possible disturbances of cardiac rhythm catecholamine drugs, such as epinephrine should only be used with special caution in situations of emergency life support.

FIRE FIGHTING MEASURES

Flammable Properties

Flash Point	Will not burn
LEL	Not Applicable
UEL	Not Applicable
Autoignition	>743 C (>1369 F)

HFC-134A is not flammable at ambient temperatures and atmospheric pressure. However, HFC-134A has been shown in tests to be combustible at pressures as low as 5.5 psig at 177 C (351 F) when mixed with air at concentrations of 60 volume % air. At lower temperatures, higher pressures are required for combustibility. Experimental data have also been reported which indicate combustibility of HFC 134A in the presence of certain concentrations of chlorine.

FIRE AND EXPLOSION HAZARDS:

Cylinders may rupture under fire conditions. Decomposition may occur. Contact of welding or soldering torch flame with high concentrations of refrigerent can result in visible changes in the size and color of the torch flame. This flame effect will only occur in concentrations of product well above the recommended exposure limit, therefore stop all work and ventilate the area before proceeding. Use forced ventilation to disperse refrigerant vapors from the work area before using any open flames.

Extinguishing Media

As appropriate for combustibles in area. Extinguishant for other burning material in area is sufficient to stop burning.

Fire Fighting Instructions

Cool tank/container with water spray. Self-contained breathing apparatus (SCBA) is required if cylinders rupture or contents are released under fire conditions.

ACCIDENTAL RELEASE MEASURES

Safeguards (Personnel)

NOTE: Review FIRE FIGHTING MEASURES and HANDLING (PERSONNEL) sections before proceeding with clean up. Use appropriate PERSONAL PROTECTIVE EQUIPMENT during clean up.

Accidental Release Measures

Ventilate area, especially low or enclosed places where heavy vapors might collect. Remove open flames. Use self-contained breathing apparatus (SCBA) for large spills or releases.

HANDLING AND STORAGE

Handling (Personnel/Physical Aspects)

Use with sufficient ventilation to keep employee below recommended limits. HFC-134A should not mixed with air for leak testing. In general it should be used or allowed to be present with high concentration air above atmospheric pressure. See Flammable Properties section. Contact with chlorine or other strong oxidizing agents should also be avoided.

Storage

Store in a Clean, dry area. Do not heat above 52 C (126 F)

EXPOSURE CONTROLS/PERSONAL PROTECTION

Engineering Controls

Normal ventilation for standard manufacturing procedures is generally adequate. Local exhaust should be used when large amounts are released. Mechanical ventilation should be used in low or enclosed places. Refrigerant concentration monitors may be necessary to determine vapor concentrations in work areas prior to use of torches or other open flames, or if employees are entering enclosed areas.

PERSONAL PROTECTIVE EQUIPMENT

Impervious gloves and chemical splash goggles should be used when handling liquid. Under normal manufacturing conditions, no respiratory protection is required when using this product. Self-contained breathing apparatus (SCBA) is required if a large release occurs.

EXPOSURE GUIDELINES

EXPOSURE LIMITS

“SUVA” 134A

PEL (OSHA)

None Established

TLV (ACGIH)

None Established

AEL * (DuPont)

1,000 ppm, 8 & 12 Hr. TWA

WEEL (AIHA)

1000 ppm, 8 Hr. TWA

* AEL is DuPont's Acceptable Exposure Limit. Where governmentally imposed occupational exposure limits which are lower than the AEL are in effect, such limits shall take precedence.

PHYSICAL AND CHEMICAL PROPERTIES

PHYSICAL DATA

Boiling Point	-26.5 C (15.7 F) @ 736 mm Hg
Vapor Pressure	96 psig @ 25 C (77 F)
Fl Vapor Density	3.6 (Air=1.0) @ 25 C (77 F)
Fl % Volatilize	100 WT%
Solubility in Water	0.15 WT%, @ 25 C (77 F) @ 14.7 psia
Odor	Slight ethereal
Form	Liquefied Gas.
Color	Clear, Colorless.
Liquid Density	1.21 g/cm ³ @ 25 C (77 F)

STABILITY AND REACTIVITY

CHEMICAL STABILITY

Material is stable. However, avoid open flames and high temperatures.

CONDITIONS TO AVOID

Avoid open flames and high temperatures.

INCOMPATIBILITY WITH OTHER MATERIALS

Incompatible with alkali or alkaline earth metals- powdered Al, Zn, Be, etc.

DECOMPOSITION

Decomposition Products are hazardous. HCFC-134A can be decomposed by high temperatures (open flames, glowing metal surfaces, etc.) forming hydrochloric and hydrofluoric acids, and possibly carbonyl halides.

POLYMERIZATION

Polymerization will not occur.

TOXICOLOGICAL INFORMATION

ANIMAL DATA

ETHANE, 1,1,1,2-TETRAFLUORO

INHALATION: 4 hour, ALC, rat: 567,000 ppm.

SKIN: The compound is a skin irritant and a slight eye irritant but is not a skin sensitizer in animals.

EYE: A short duration spray of vapor produced very slight eye irritation.

Effects from single high exposures include central nervous system depression, anesthesia, rapid breathing, lung congestion and microscopic liver changes. Cardiac sensitization occurred in dogs at 50,000 ppm or greater from the action of exogenous epinephrine.

No toxic effects or abnormal histopathological observations occurred in rats repeatedly exposed to concentrations ranging from 10,000 to 50,000 ppm (v/v). Long-term exposures to 50,000 ppm (v/v) of vapors produced organ weight increases and a decrease in body weight gain, but no increased mortality or adverse hematological effects. In chronic inhalation studies, HCFC-22, at a concentration of 50,000 ppm (v/v), produced a small, but statistically significant increase of late-occurring tumors involving salivary glands in male rats, but not female rats or male or female mice. In the same studies, no increased incidence of tumors was seen in either species at concentrations of 10,000 ppm or 1,000 ppm (v/v).

Long-term administration in corn oil produced no effects on body weight or mortality.

HCFC-22 was mutagenic in some strains of bacteria in bacterial cell cultures, but not mammalian cell cultures or animals. It did not cause heritable genetic damage in

(Continued)

2008FR

(Continued)

TOXICOLOGICAL INFORMATION (Continued)

mammals.

Single exposure caused: Cardiac sensitization, a potentially fatal disturbance of heart rhythm associated with a heightened sensitivity to the action of epinephrine. Lowest-Observed-Adverse-Effect-Level for cardiac sensitization: 75,000 ppm. Single exposure caused: Lethargy. Narcosis. Increased respiratory rates. These effects were temporary. Single exposure to near lethal doses caused: Pulmonary edema. Repeated exposure to caused: Increased adrenals, liver, spleen weight. Decreased uterine, prostate weight. Repeated dosing of higher concentrations caused: the following temporary effects- Tremors. Incoordination.

CARCINOGENIC, DEVELOPMENTAL, REPRODUCTIVE, MUTAGENIC EFFECTS:

In a two-year inhalation study, HFC-134A, at a concentration of 50,000 ppm, produced an increase in late-occurring benign testicular tumors, testicular hyperplasia and testicular weight. The no-effect-level for this study was 10,000 ppm. Animal data show slight fetotoxicity but only

ECOLOGICAL INFORMATION

ECOTOXICOLOGICAL INFORMATION

Aquatic Toxicity:

HCFC-22 48 hour EC50 - Daphnia magna: 433 mg/L

DISPOSAL CONSIDERATIONS

WASTE DISPOSAL

Comply with Federal, State, and local regulations. Reclaim

Comply with Federal, State, and local regulations. Red by distillation or remove to a permitted waste disposal facility.

TRANSPORTATION INFORMATION

SHIPPING INFORMATION

DOT/IMO Proper Shipping Name	CHLORDDIFLUOROMETHANE
Hazard Class	2.2
UN No.	1018
DOT/IMO Label	NONFLAMMABLE GAS

Shipping Containers

Tank Cars.
Tank Trucks.
Cylinders.

(Continued)

2008FR

(Continued)

REGULATORY INFORMATION

U.S. FEDERAL REGULATIONS

TSGA Inventory Status Reported/Included.

TITLE III HAZARD CLASSIFICATIONS SECTIONS 311, 312

Acute : Yes
Chronic : No
Fire : No
Reactivity : No
Pressure : Yes

HAZARDOUS CHEMICAL LISTS

SARA Extremely Hazardous Substance	:	No
CERCLA Hazardous Substance	:	No
SARA Toxic Chemical	- See Components Section	

OTHER INFORMATION

NFPA NPCA-HMIS

NPCA HMIS

Health	1
Flammability	0
Reactivity	1

Personal Protection rating to be supplied by user depending on use conditions.

The data in this Material Safety Data Sheet relates only to the specific material designated herein and does not relate to use in combination with any other material or in any process.

Responsibility for MSDS	: DuPont Chemicals
Address	: Engineering a Product Safety
➤	: P.O. Box 80709, Chestnut Run
➤	: Wilmington, DE 19880-0709
Telephone	: (302) 999-4946

Indicates updated section.

End of MSDS

2008FR

Controller Operation Guide (S-Series)



Keypad Functions:

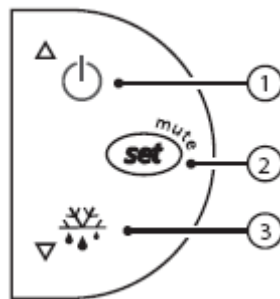

Figure 1

Button 1 (Up Arrow):

Pressing this button raises the selected value.

Button 2 (Set):

Pressing this button for 1 second allows access to the “set-point” of the chiller.

Pressing this button for 3 seconds will allow access to the “set-point differential”, “password” and “°C/°F” of the chiller.

Button 3 (Down Arrow):

Pressing this button lowers the selected value.

***Note: Password is used to access additional parameters in the controller. This should only be accessed by a certified technician.**

Changing the “set-point”:

To change the “set-point”, hold the “Set” key (see Keypad Functions) for 1 second until you see the letters ‘st’. Then press the set key again to access the set-point. Use the “Up Arrow” and “Down Arrow” keys to change the value. Once to the desired value, press the “Set” key again to store the value.

***Note: The set-point can be set between 50°F and 90 °F**

Changing the “set-point differential”:

To change the “set-point differential”, hold the “Set” key (see Keypad Functions) for 3 seconds until you see the letters ‘Pw’. Then use the arrow keys to scroll through the menus until you see the letters ‘rd’. Then press the set key again to access the set-point differential. Use the “Up Arrow” and “Down Arrow” keys to change the value. Once to the desired value, press the “Set” key again to store the value.

***Note: The set-point differential should be set between 3°F and 10 °F**

Changing the temperature display (°C/ °F):

To change the temperature display, hold the “Set” key (see Keypad Functions) for 3 seconds until you see the letters ‘Pw’. Then use the arrow keys to scroll through the menus until you see ‘/5’ on the display. Then press the set key again to access the display settings. Use the “Up Arrow” and “Down Arrow” keys to change the value.

**Note: 0 = °C, 1 = °F*

Controller Operation:

When power is applied to the controller the temperature of the sensor in the piping is displayed. If the temperature rises above the set-point (st) by the set-point differential (rd), the compressor is turned on. Once the temperature reaches the set-point the compressor is turned off. See *Figure 2* below:

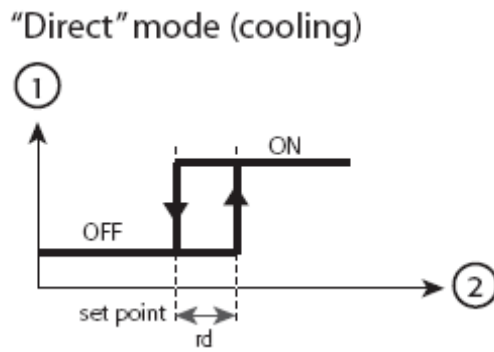
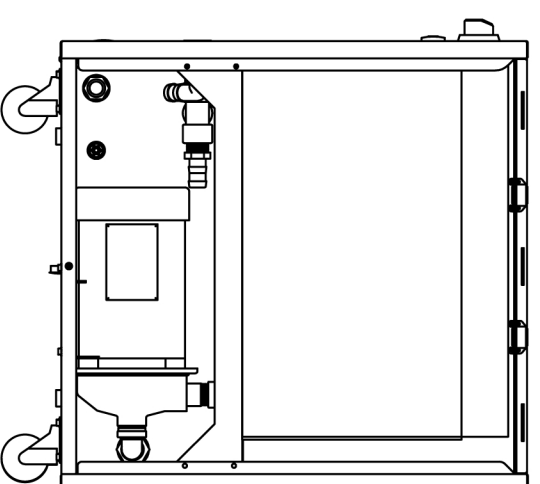
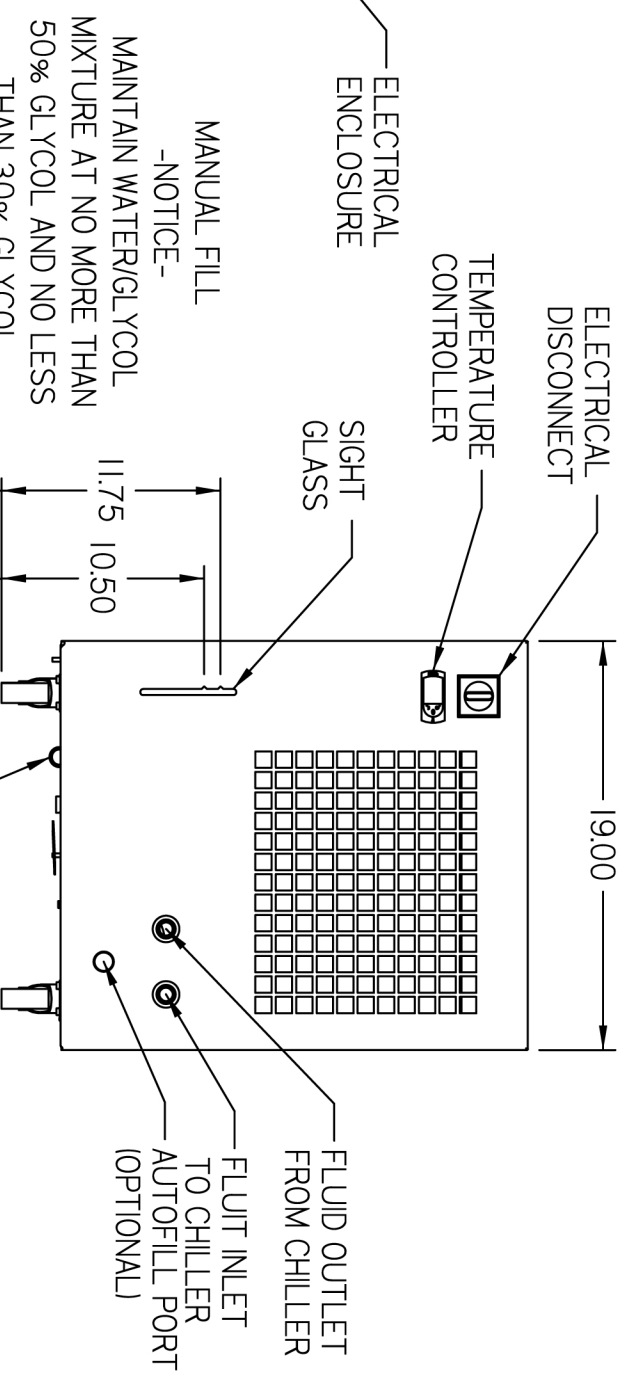
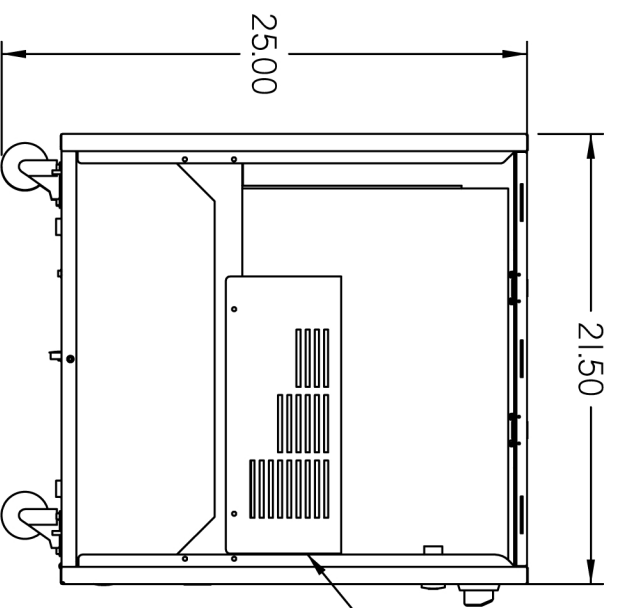
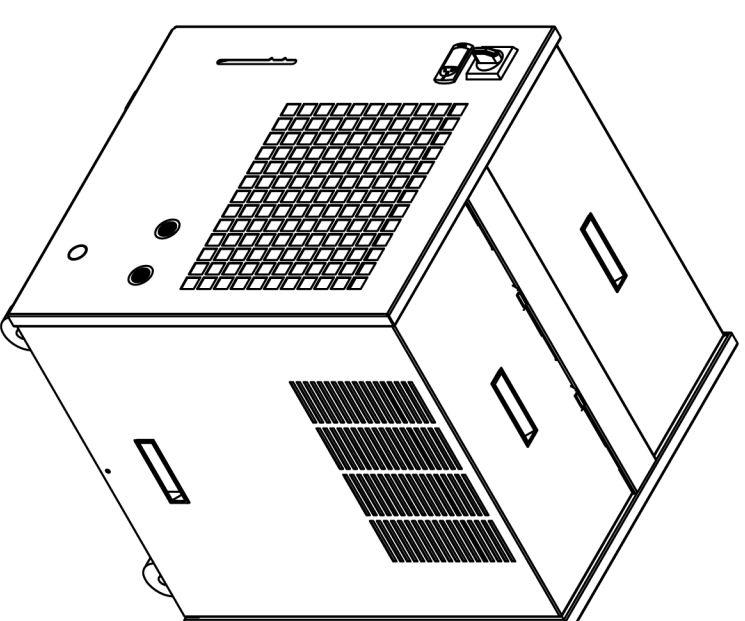
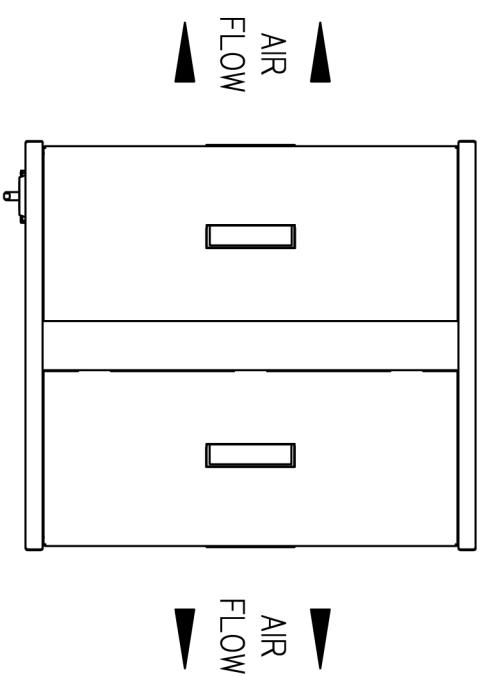
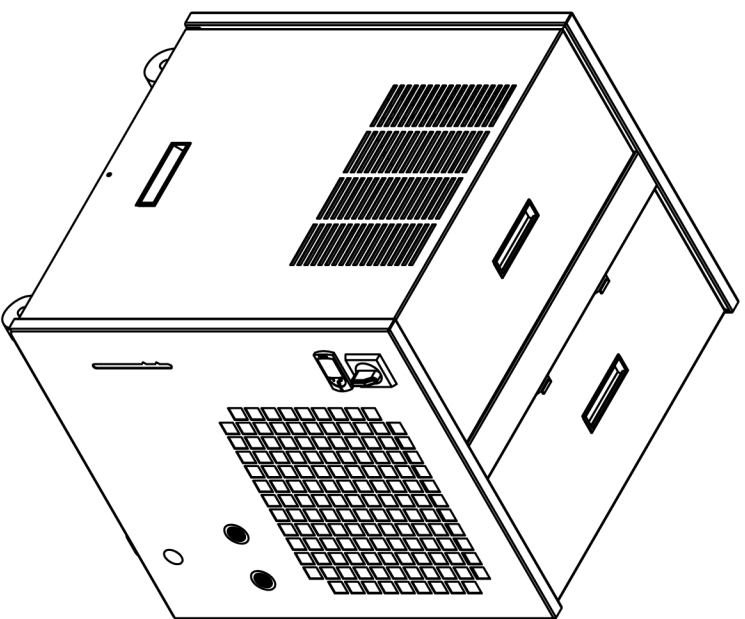

Figure 2



* PARTS NOT SHOWN ON DRAWING DETAIL

ALL DIMENSIONS ARE IN INCHES

THIS PRINT MAY NOT BE DUPLICATED, REPRODUCED, OR SHARED IN ANY WAY WITHOUT EXPRESSED WRITTEN CONSENT

CONFIDENTIAL AND PROPRIETARY

DATE	DESCRIPTION OF REVISION	APPROVED BY

* PARTS NOT SHOWN ON DRAWING DETAIL

DESIGN BY: AWK	DRAWN BY: AWK	DATE: 08/06/09	PAGE: 1 OF 1
----------------	---------------	----------------	--------------

LAYOUT

DRAWING NO. 442082



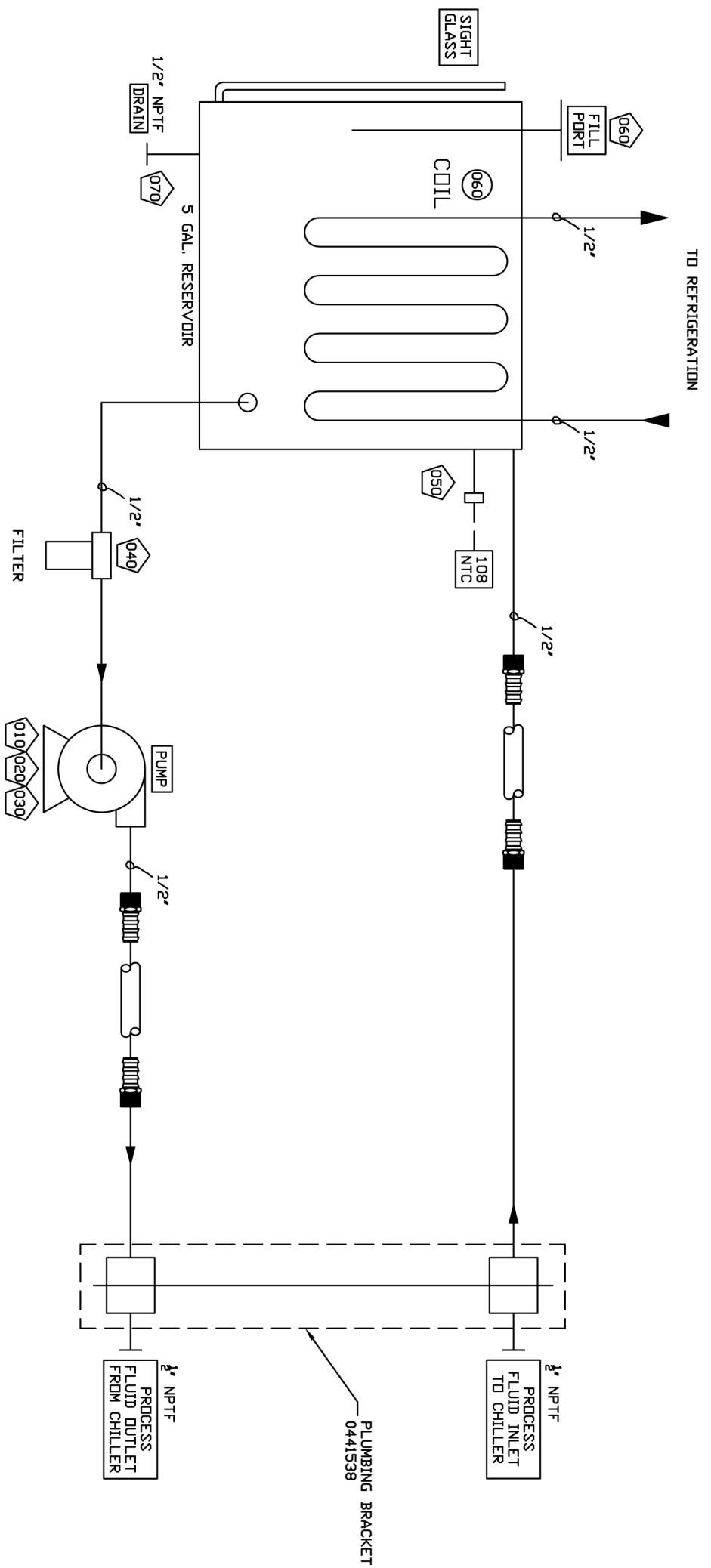

NO.	PIPING PARTS	1D/DESCRIPTION	K.K. PART #	QTY	TYPE
001		JH/AN/MH-3T 300 MCHNG	0441751	1.0	PC
010		104B240F 11BC PUMP VALVE 240 GPH SOLID RELIEF VALVE 2 99 PSI REQUR ES NEMA 4BYZ MOTOR FORMER MODEL CBE 507XH (PRE 4-1-97) PRODCN REBULID K 11 # 1P4B240F11BC *****BERNS# P0801A WITH PUMP ADAPTER***** 3K987 MOTOR 48Y FRAME 1/3 HP 1 PH 100-120/200-240 VOLTI 50/60 HZ CAR BINATOR MOTOR 5.6/2.8 AMPS 142 5/1725 RPM GE # 5KH32GNS588X (CAT # 4805) DLD #5K987, REPLACED BY THE ABOVE MOTOR. GRATINGER 1113 CLAMP V-BAND PRODCN 030	1732603	1.0	PC
040		D3350-0043P FILTER 1/2"NPT 80 MESH STANDARD SIZE NYLON VLENF BUN-N CASKEIT CLEAR BUNL (OLD #4688 TA LEIT INDUSTRIES) 4" 150 PSI #707 0 PSI AT 125F, 140F MAX TEMPERATURE 1 HYPRD 050	4330900	1.0	PC
050		1/2 SENSOR ASSEMBLY FOR CAREL MP0617671 10K THERMISTOR 10" CAREL PLATINUM, 2 WIRE CONSTRUCTION WITH DRAIN WIRE ATTACHED TO SHEATH, 3/16 DIA SHEATH, 316 SST 5-1/2 OVERALL LENGTH, 4-1/2 HOT LEG WITH 90° BEND PVC LEAD-WIRE (300 VAC RATED) WITH SHIELD AND DRAIN, 10 FT LONG GREY WIRE COVER, NO COLD END TERMINATION GENERALLY USED ON 15 TON UNITS AND BELOW, WITH 4 POINT CRIMP CLASS A SENSORTIC 020	0611318 4801215	1.0 1.0	PC PC
060		COMPRESSION FITTING 1/2" NPT X 3/16 TUBE BRASS 070	7504920	1.0	PC
070		DECK FILL CAP 1-1/2" SFA DUG # 357034C2 080	7412915	1.0	PC
080		FLUG 1/2" MPT BR3 SQ HEAD HOSEBARB 1/2" MPT X 1/2" HOSE 90 POLY 090	7504900 7410231	1.0 3.0	PC PC
090		HOSEBARB 1/2" MPT X 1/2" HOSE POLY NIPPLE 1/2" MPT X SHORT POLY 110	7404105 7404105	3.0 3.0	PC PC
100		TEE 1/2" FPT POLY HOSEBARB 1/8" MPT X 1/4" HOSE BR3 120	7404101 7501901	2.0 1.0	PC PC
110		WHEEL CASTERS VLD60075 1" X 3" # 110 # STANDARD FLAT BOTTD MED RUBBER BRAKE CASTER 130	4500020	4.0	PC

ALL DIMENSIONS ARE IN INCHES

THIS PRINT MAY NOT BE
DUPLICATED, REPRODUCED, OR SHARED IN ANY WAY
WITHOUT EXPRESSED WRITTEN CONSENT

CONFIDENTIAL AND PROPRIETARY

* PARTS NOT SHOWN ON
DRAWING DETAIL

DESIGN BY: AWK DRAWN BY: AWK
DATE: 07/14/09 PAGE 1 OF 1

180/500-11/21-V

PIPING

DRAWING NO.
441751

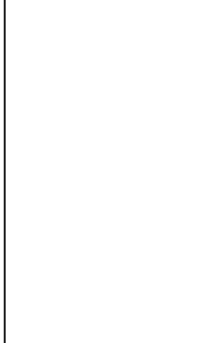

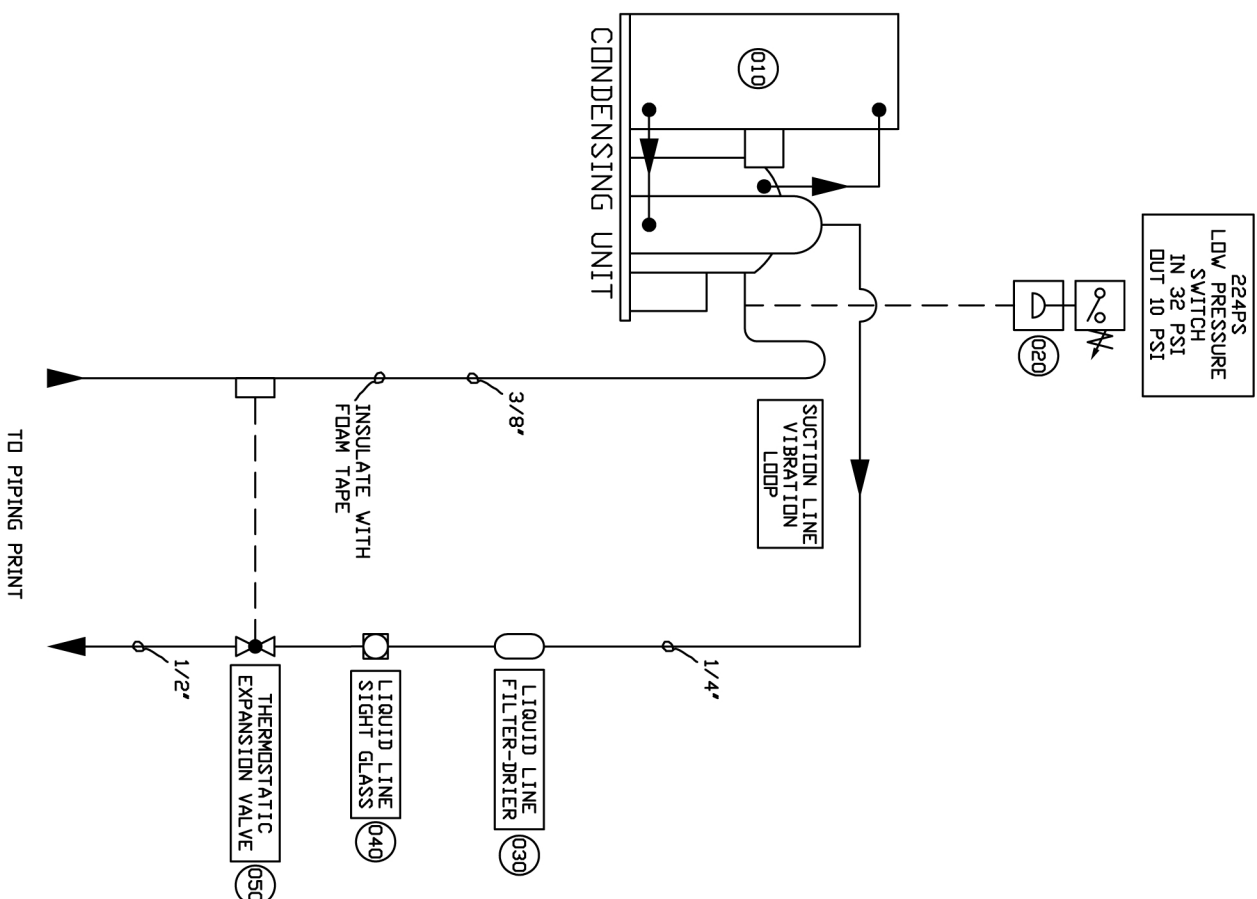

224PS
LOW PRESSURE
SWITCH
IN 3/2 PSI
OUT 10 PSI



REFRIGERATION PARTS	QTY	TYPE
001	1.0	PC
010	1.0	PC
020	1.0	PC
030	1.0	PC
040	1.0	PC
050	1.0	PC
060	1.0	PC
070	0.5	PC
080	2.0	PC
090	2.5	PC
100	1.0	PC

NO.	11/DESCRIPTION	K.K. PART#	QTY	TYPE
001	JIMMBO REFRIG 115/1/60	0441594	1.0	PC
010	4EA44301XAXA BMEC409-1 CONDENSING UNIT R-134A 1/6 HP 115/1/60 100/1/50 USED IN J1180-TECUMSEH FAN MOTOR# 810M006B45 COMPRESSOR B/M AE54 OAR-231-A2	1300038	1.0	PC
020	LOW PRESSURE SWITCH 10/20 PSI, CUT OUT SWITCH 10/20 PSI, CUT OFF T 10 PSI CAN BE USED AS LP FOR 134 A. FORMERLY 10/32 SWITCH, JOHNSON CONTROL'S P100AF-201CCP100AA-121 RE SOURCE DISTRIBUTION YK-03L 0110-010 EDOZE	3644006	1.0	PC
030	C-0325 FILTER DRIER 1/4"	2730001	1.0	PC
040	SPORLAN SA-125 SIGHT GLASS 1/4 ODF	2720001	1.0	PC
050	SPORLAN CP80 VALVE EXPANSION	2760068	1.0	PC
060	EBF-TAN CP80 VALVE EXPANSION	7399080	1.0	PC
070	DRAWING 303279, AC FAB INSULATION TAPE GASKET .25 X 2 X 50 NITRILE/PVC BLEND, CLOSED CELL SPO NGE RUBBER, TEMPERATURE RANGE: -20 TO 160F, INTERMITTENT 220F, CAN BE USED AT 200F CONTINUOUS PER GRP. GR R RUBBER PRODUCTS TUBING 1/4 SOFT COPPER REFRIG TUBING 3/8 SOFT COPPER REFRIG 50' ROLL	7302000 7303000 2990135	2.0 PC 2.5 PC 1.0 PC	PC

* PARTS NOT SHOWN ON DRAWING DETAIL

ALL DIMENSIONS ARE IN INCHES
THIS PRINT MAY NOT BE
DUPLICATED, REPRODUCED, OR SHARED IN ANY WAY
WITHOUT EXPRESSED WRITTEN CONSENT
CONFIDENTIAL AND PROPRIETARY

DATE	DESCRIPTION OF REVISION	APPROVED BY
06/11/10	ITEM 060 WAS 7399082	AWK (A)

DESIGN BY: AWK
DATE: 06/22/09
DRAWN BY: AWK
PAGE 1 OF 1
REFRIGERATION
LS 180-11
DRAWING NO. 441594



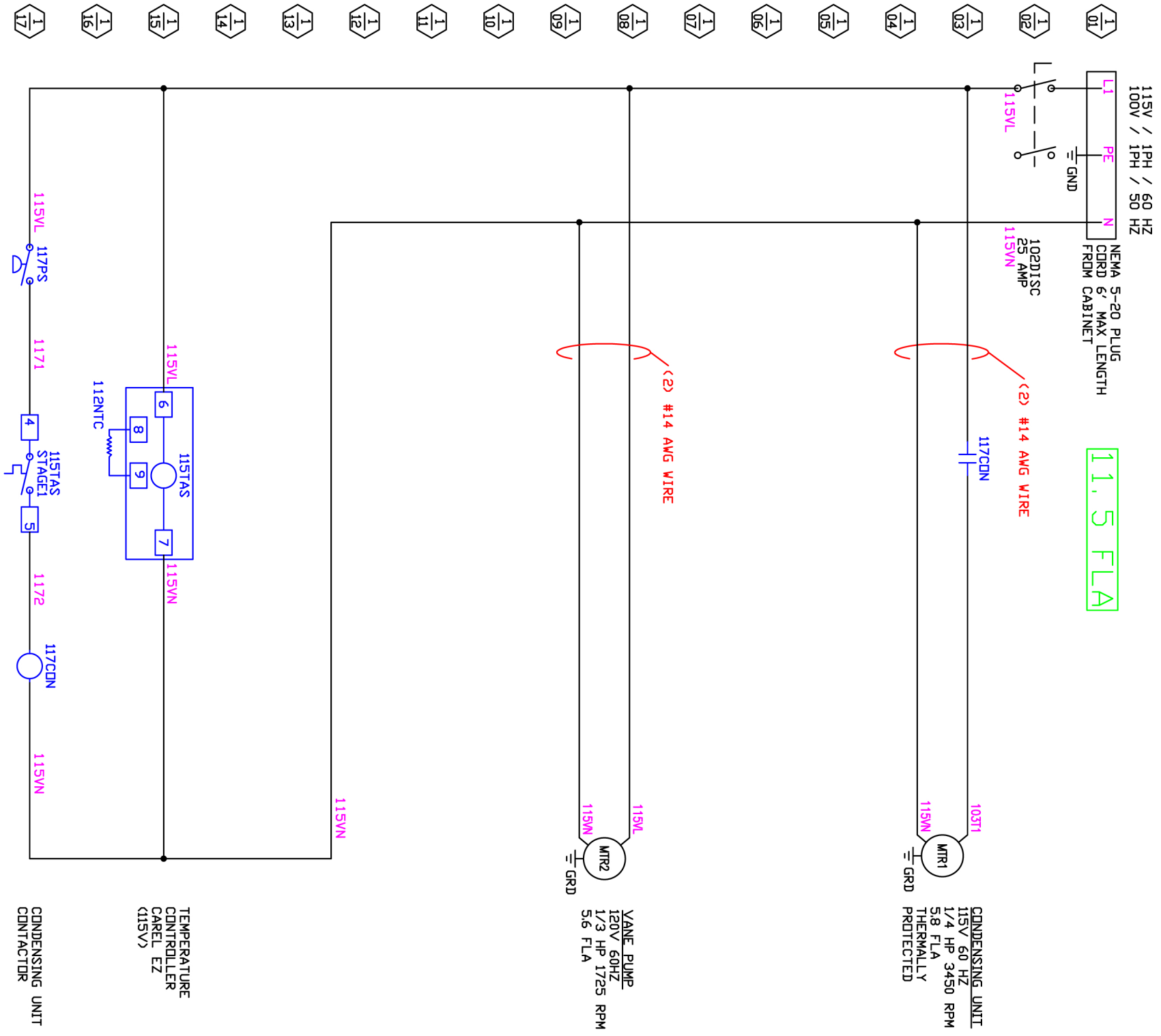

11.5 FLA

CONDENSING UNIT
115V 60 HZ
1/4 HP 3450 RPM
5/8 FLA
THERMALLY
PROTECTED

VANE PUMP
120V 60HZ
1/3 HP 1725 RPM
5/6 FLA

TEMPERATURE
CONTROLLER
CAREL EZ
(115V)

CONDENSING UNIT
CONTACTOR

- 1/21
- 1/22
- 1/23
- 1/24
- 1/25
- 1/26
- 1/27
- 1/28
- 1/29
- 1/30
- 1/31
- 1/32
- 1/33
- 1/34
- 1/35
- 1/36
- 1/37
- 1/38

ALL DIMENSIONS ARE IN INCHES

THIS PRINT MAY NOT BE
DUPLICATED, REPRODUCED, OR SHARED IN ANY WAY
WITHOUT EXPRESSED WRITTEN CONSENT

CONFIDENTIAL AND PROPRIETARY

DATE	DESCRIPTION OF REVISION	APPROVED BY

DESIGN BY: AWK	DRAWN BY: AWK
DATE: 08/06/09	PAGE 1 OF 2
IS 180-11	
ELECTRICAL	
DRAWING NO. 442080	



TAG TO ES-002 STANDARD

FRONT PANEL

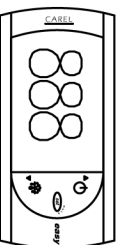
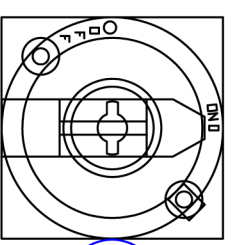

ELECTRICAL PANEL

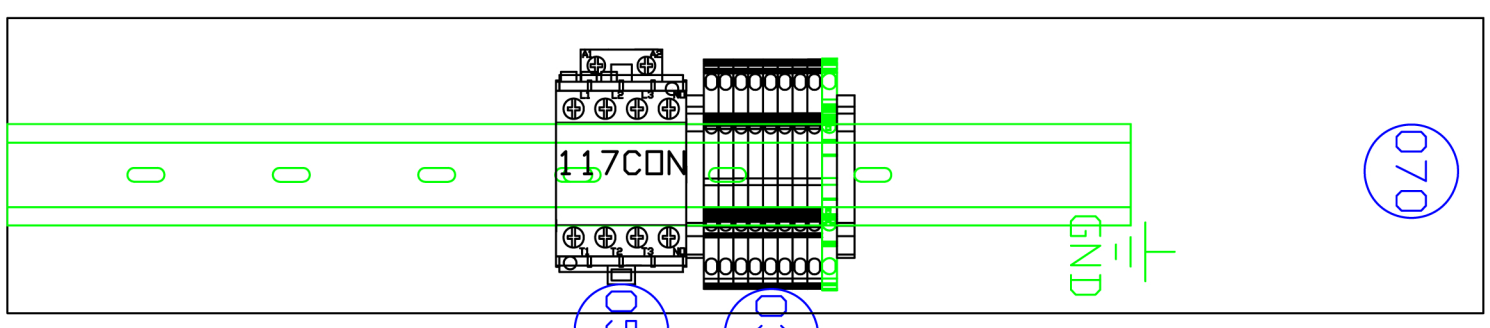

CONDENSING UNIT E-BOX

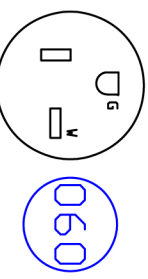
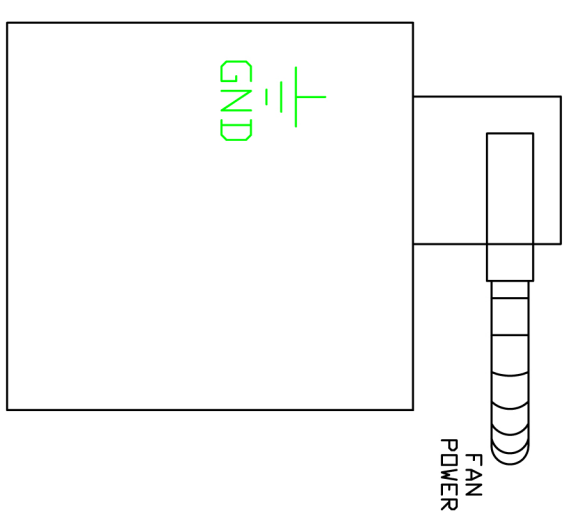

NEMA 5-20
PLUG AND CORD
MAXIMUM 6'
FROM CABINET

* PARTS NOT SHOWN ON
DRAWING DETAIL

QTY	TYPE	K. K. PART #	ID/DESCRIPTION	IND.
1.0	PC	3110103	LS 180-11 ELECTRICAL BDM	001
1.0	PC	3110103	CONF5SD SWITCH 25AMPS MAX 3 POLE, ON/OFF/O, FRONT/DOOR JDI S NOT INCLUDE HANDLE BUSSMAN *** **8/19/05, CHANGED TO BUSSMAN C3 PD LED **MOLD A/B# 194L-E20-1752 (2 PD LED) ***	010
1.0	PC	3110102	CHITOS SWITCH HANDLE SNAP DN RED/LELDN, ACCEPTS PADLOCK 0-1 MA KINGS, 48MM X 48MM BUSSMAN **8/19 /05 CHANGE D TO BUSSMAN OLD AB # 19 4L-HE4L-175 ***	020
1.0	PC	0606532	10 IEC TERMINAL BLOCKS A-B 1492-L03 AVG 22-12 600V AC/DC 30A 30PCS/PT	030
11.0	PC	3123021	1492-L30 TERMINAL BLOCK (20 AMP)	010
1.0	PC	3123086	ALLEN BRADLEY 1492-ERL35 END BARRIER (20 AMP)	020
4.0	PC	3123087	ALLEN BRADLEY 1492-ERL35 END ANCHOR(20/50 AMP)	030
1.0	PC	3123017	ALLEN BRADLEY 1492-LG30 GROUNDING BLOCK (20 AMP)	040
0.1	PC	3123095	ALLEN BRADLEY 1492-CJK510 JUMPER (20 AMP)	050
1.5	PC	3127100	ALLEN BRADLEY 199-DRT MOUNTING RAIL 199-RDY 1 METER LONG ALLEN BRADLEY PIEZOSDS00 CONTROLER, BLUE 5PC/RDY NTC PROBE INPUT 2 D 15VAC POWER NTC PROBE INPUT 2 D DIGITAL OUTPUTS, 1 ST-SV, 3 DIGIT BLD E-LED DISPLAY, CAREL	060
1.0	PC	3100200	100-C09D10 CONTACTOR 120VAC COIL	050
1.0	PC	3807115	ALLEN BRADLEY PLUG WITH CORD 12/3 SJT 20A 125V WITH NEMA 5-20 PLUG 10 FEET OF CDR D	060
1.0	ASSEM	0441667	500 EBOX BASE	070
3.0	LB		SHEET 18 GA GALV.	010

- NOTES:
- 1) MAKE ALL CONTROL POWER WIRES BLACK EXCEPT NEUTRAL.
 - 2) GROUND BLOCKS LABEL WITH GROUND SYMBOL.
 - 3) ALL COMPONENTS MUST BE TOUCH SAFE.
 - 4) "PE" LABEL ON A SILVER SERIAL NUMBER TAG REQUIRED AT GROUND TERMINAL STRIP
 - 5) TERMINAL BLOCKS TO BE MARKED IN INK OR MARKER, NOT PENCIL

ALL DIMENSIONS ARE IN INCHES

THIS PRINT MAY NOT BE
DUPLICATED, REPRODUCED, OR SHARED IN ANY WAY
WITHOUT EXPRESSED WRITTEN CONSENT

CONFIDENTIAL AND PROPRIETARY

DATE	DESCRIPTION OF REVISION	APPROVED BY
06/30/10	REMOVED NOTE FOR TB	CJH (B)
06/16/10	REVISED NOTES FOR BLACK WIRE	TM (A)
03/08/10	ADDED EBOX BASE TO BDM	AWK

DESIGN BY: AWK
DATE: 08/06/09

DRAWN BY: AWK
PAGE 2 OF 2

LS 180-11
ELECTRICAL

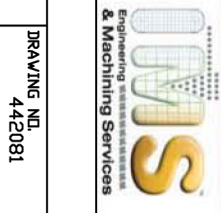

DRAWING NO:
442081